

MODEL	RAD-0600A-3
VOLTAGE	230V-3PH-60HZ
RLA	11.4
LRA	55
MCA	11.7
MOP	30
COMPRESSOR HP	3-1/2
COMPRESSOR	SCROLL
REFRIGERANT	R449A
REFRIGERANT CHARGE (OZ)	96
MAX INLET AIR TEMP (F)	140
MAX INLET AIR PRESSURE (PSI)	232
MIN/MAX AMBIENT TEMP (F)	45/120
REFRIGERANT PRESSURE RANGE (PSI)	181-450
INLET/OUTLET PORT (NPT)	2-1/2
WEIGHT	500

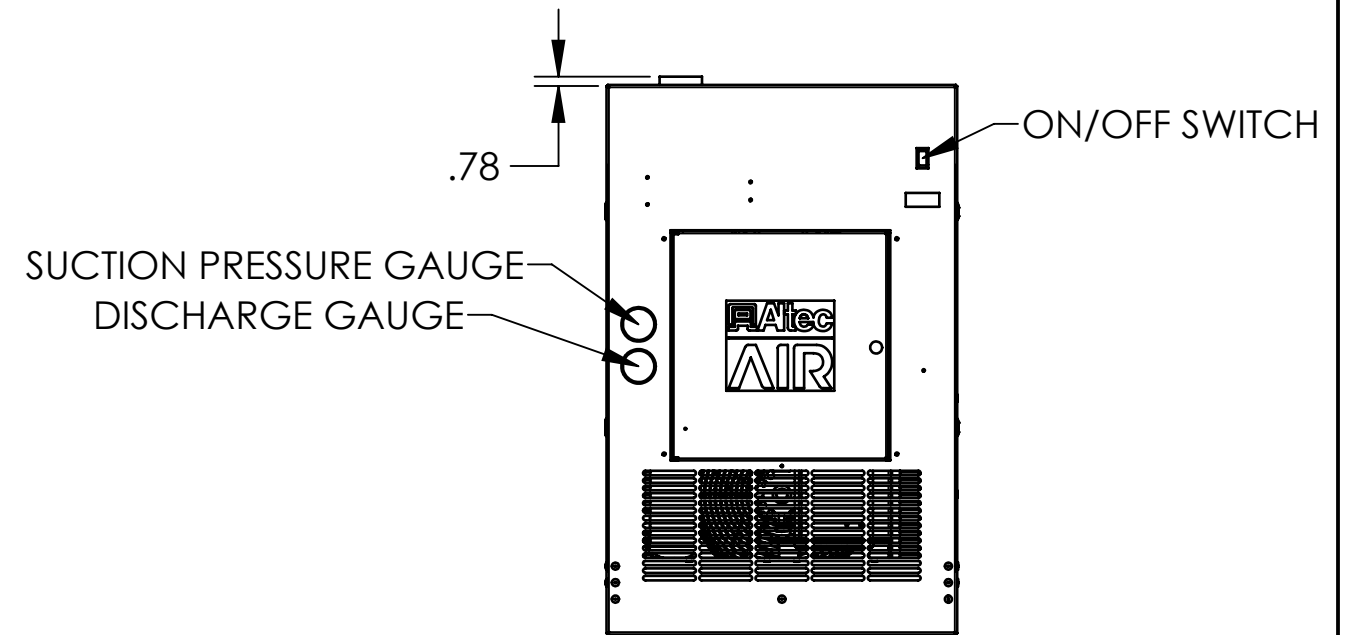

DRAWN	J. GAMBLE	UNLESS OTHERWISE NOTED, TOLERANCES ARE: FRACTIONS: $\pm 1/16$ ANGLES: $\pm 0^{\circ}30'$ DECIMAL: .X = $\pm .06$.XX = $\pm .03$.XXX = $\pm .015$.XXXX = $\pm .0030$ MACHINED SURFACES: 125 MICRINCHES THESE TOLERANCES DO NOT APPLY TO BASIC DIMENSIONS.
APPROVED	-	
DATE	10/20/2022	
MATERIAL		
FINISH		
TITLE: DRYR-REFRIG; NON-CYCL; 500 SCFM; 575V/3PH; 60 HZ		
CONFIDENTIAL: This drawing and its contents are the proprietary and confidential information of Altec Industries, Inc. and are not to be reproduced, copied or publicly disclosed. If this drawing is provided to someone outside Altec, it is done so for the limited purpose of assisting that recipient with a technical or product issue. In receiving this drawing, the recipient agrees to maintain it in confidence and not to use it beyond the purpose previously stated. Recipient agrees not to reproduce, copy, or publicly disclose this drawing and its contents.		

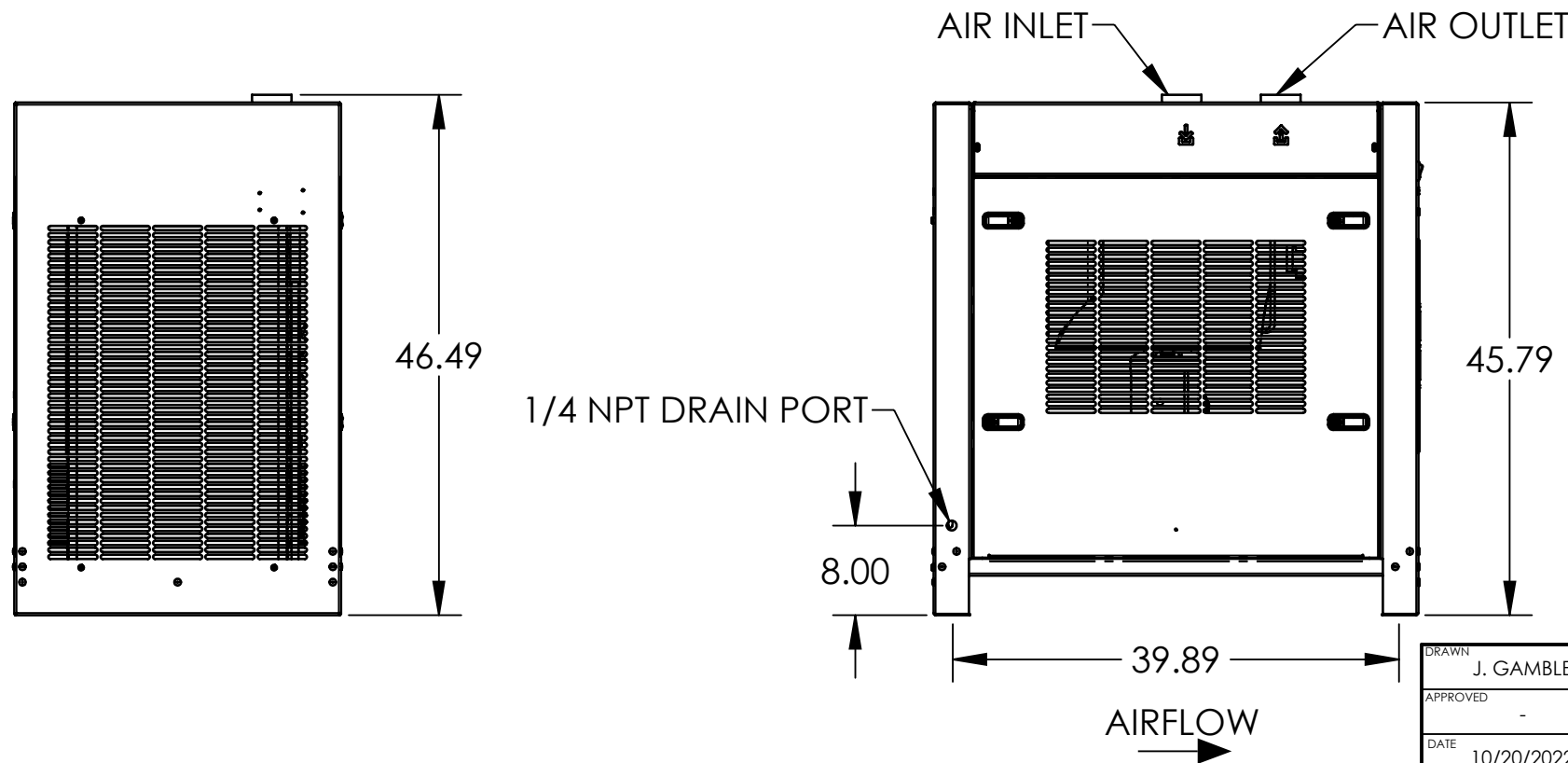
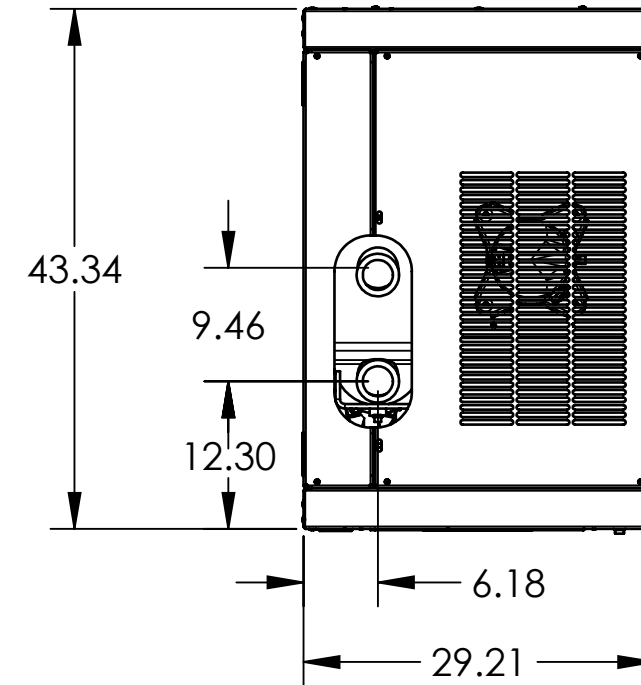
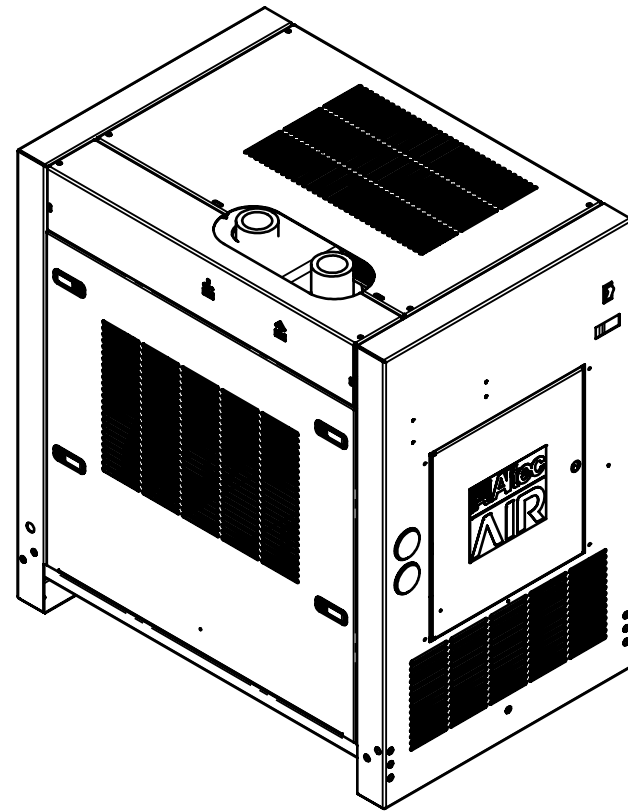

SCALE	WEIGHT	SIZE	NUMBER	REV
1:16		2	100520488	B